

ApenGroup®



Aquapump Hybrid

Integrated Compact Unit

Heat Pump + Boiler

ApenGroup®
aermaxline



Apen Group, **CARING FOR THE ENVIRONMENT**

Environmental issues are one of our top concerns.

We are constantly facing the challenge of innovating our range to minimize the environmental impact of our products.

“Caring for the environment” is not just a slogan: in our experience, it concerns our entire company structure, from finding out partners and suppliers that share our vision, to our staff and the setup of a protocol of prevention, control, and correction procedures to guarantee that quality and environmental goals are reached.

INTERNATIONAL CERTIFICATES

ACCREDITATION

Apen Group's products have been tested and certified by Gastec-Kiwa CERMET, the famous Dutch Notified Body, with test labs accredited by the EC.

Our condensation boiler has undergone severe working tests and its efficiency levels have been certified and assigned pin code 0694BT1623.

The cooling and heat pump unit is tested according to the most advanced and rigorous protocols with automatic controls to assure premium efficiency and reliability levels.



RESEARCH AND INNOVATION FOR THE HEATING

AquaPump Hybrid is a hybrid appliance in just one product, the only all-in-one unit of this type on the market.

It is designed to enhance environment protection through minimizing pollutants, guaranteeing top efficiency and reducing energy consumption. Aquapump Hybrid turns originality, reliability and care for the environment into a product standard, delivering optimum heating and conditioning conditions for small to large spaces.



PACKAGED SYSTEM

AQUAPUMP HYBRID is a packaged unit for outdoor installation, designed for hot or cold water production from renewable energy sources.

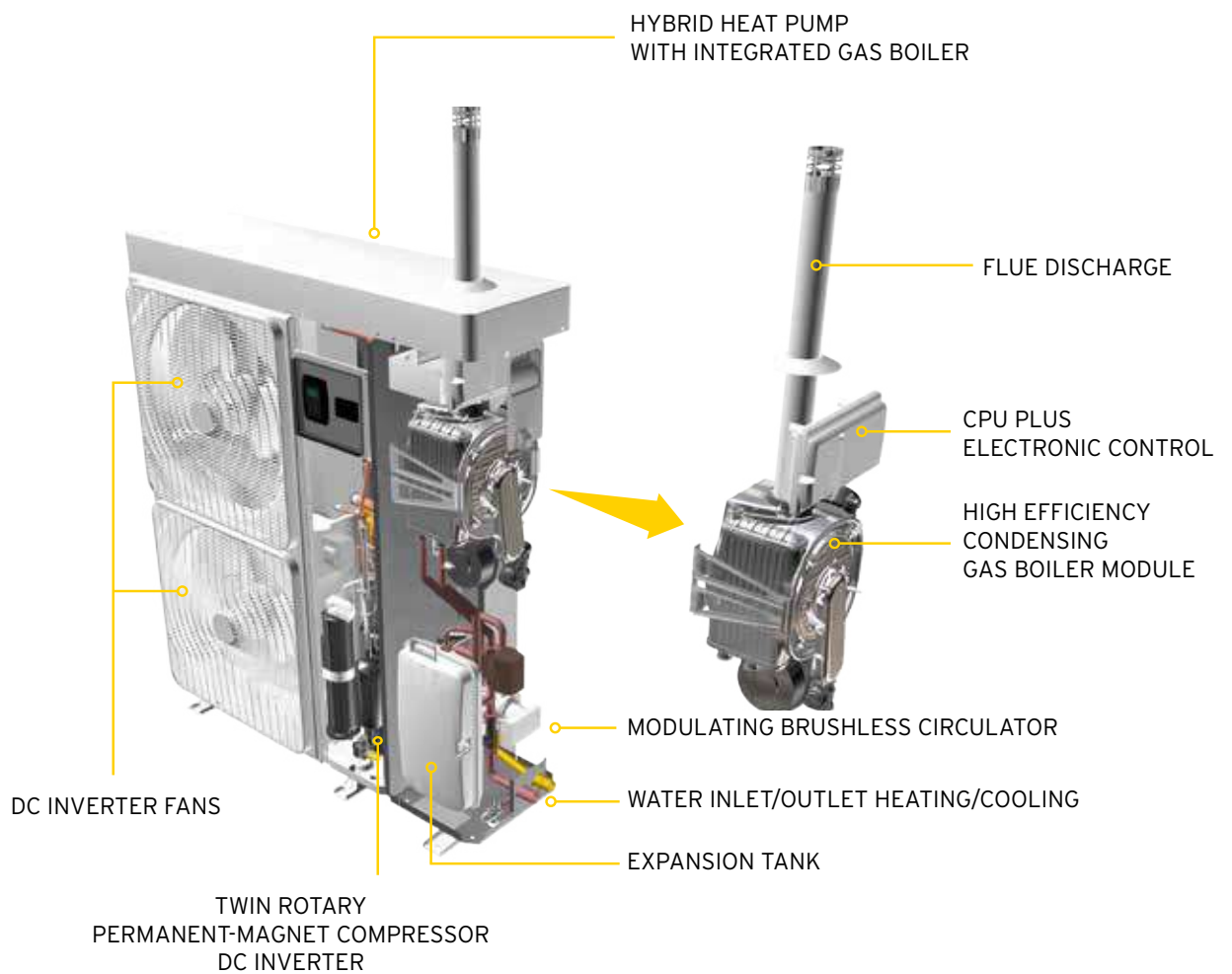

IT CAN BE COMBINED WITH A PHOTOVOLTAIC AND SOLAR MODULE.



DOMAINS OF APPLICATION

AquaPump Hybrid includes several features that make it perfectly and efficiently be used in multiple domains, assuring top temperature comfort both in winter and in summer when installed with traditional or last generation terminals.

INDUSTRIAL

Premises, workshops, warehouses.



COMMERCIAL

Stores, supermarkets, showrooms, bars, restaurants.



SERVICES

Gymnasiums, public buildings, offices, religious buildings.



RESIDENTIAL

Single family dwellings, small blocks of flats (4-6).



AQUAPUMP HYBRID INSTALLATION SIMPLE AND EASY

AquaPump Hybrid is plug and play: it includes self-regulating features that make it simple and easy to install. Installer's work is eased since the unit is preassembled, pre-adjusted, and values are already set.

You only need to have water intake and delivery connected to hydraulic system, as well as gas and power supplies enabled. Then, just plug it in!



INSTALLATION DIAGRAM / TECHNICAL CONNECTIONS

HEAT PUMP OR BOILER ?

This packaged system, formed by a condensation boiler and an hydronic heat pump with inverter (pre-assembled with a sealed and tested R410A cooling circuit) is managed through a Smart Easy or Smart Web Control.

These controls **prioritize air-water heat pump operation**

Condensation boiler automatically triggers on only when temperature conditions around the system do not allow optimum exploitation of renewable energy sources or when the output required from the system is higher than the output efficiency of the heat pump.

Modulation of operation capacity of both systems is adjusted so that priority is always given to the heat pump. Each system has its own adjustment curve and different set points for delivery, according to the working mode you have chosen.

In order to maximize heat pump performance, you can choose to enable maximum energy savings, setting an outdoor temperature limit (+3°C, for instance) below which heat pump is turned off. In systems where electric power comes from renewable sources (photovoltaic), the heat pump can work at lower outdoor temperatures (even below 0°C) provided and anti-freeze kit is installed.

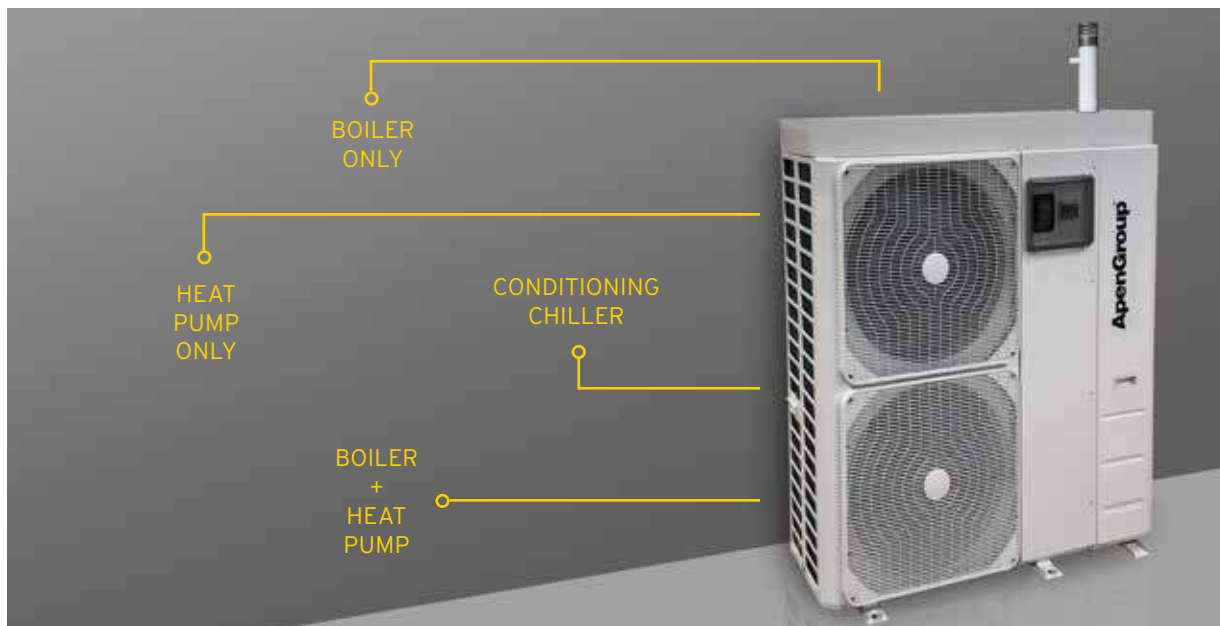

ONE PRODUCT, MULTIPLE FUNCTIONS

SYSTEM LAYOUTS

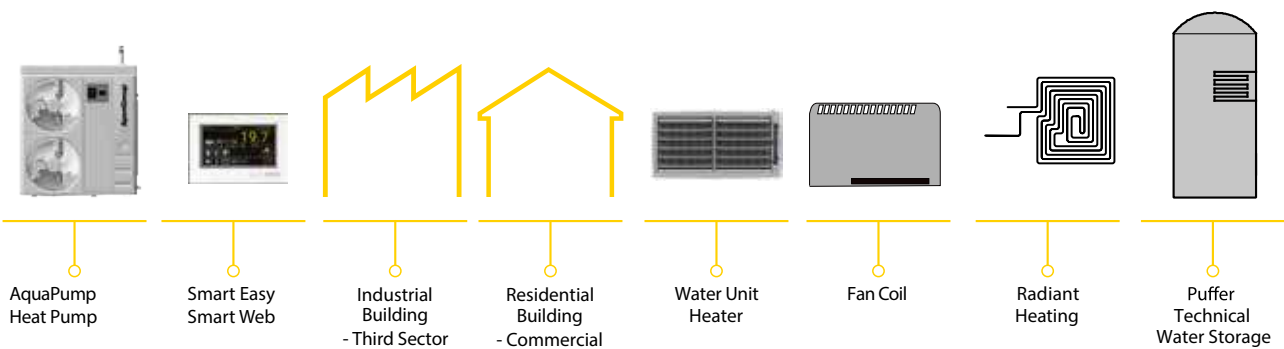
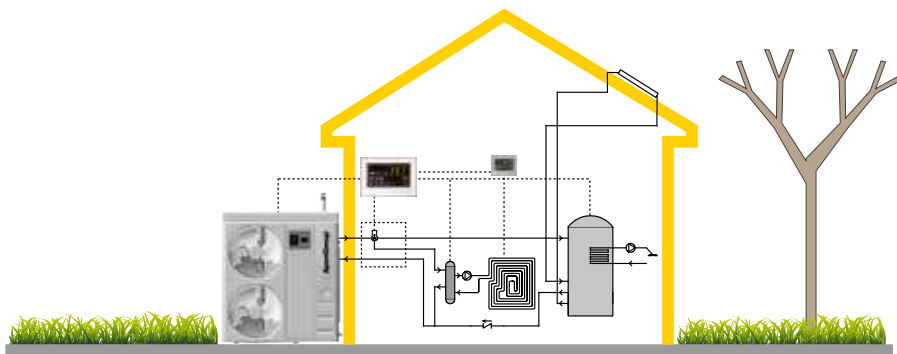
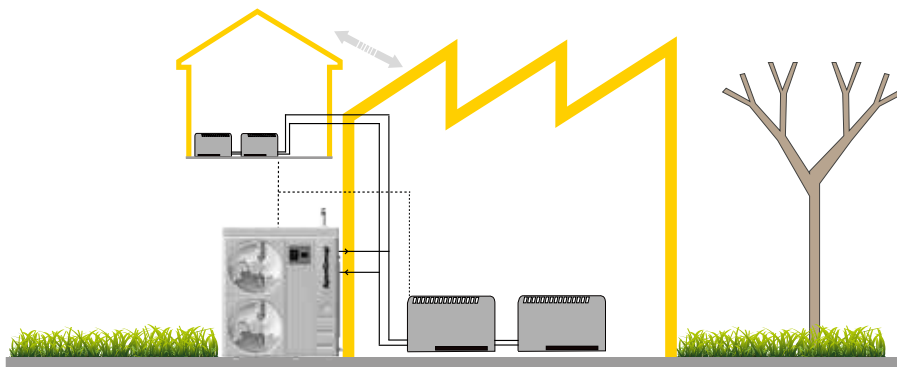
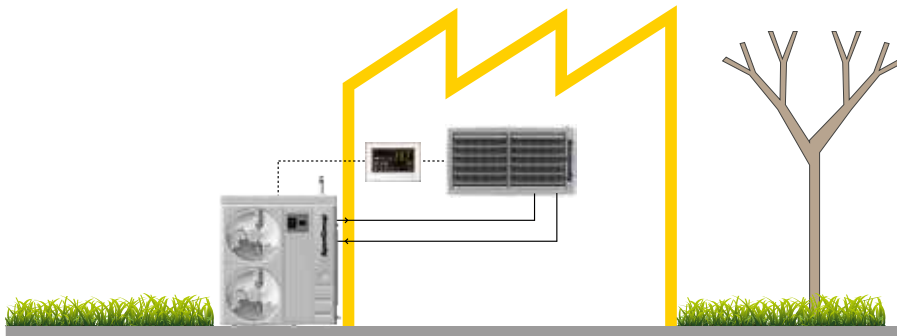

THE COMFORT OF HOT DOMESTIC WATER

No device, additional electrical resistance, nor antilegionella system is required in this hot domestic water system.



To produce hot domestic water, a puffer has to be installed, providing an additional storage boiler for technical water. A rapid heat exchanger will then be used to produce hot water. The combination of a puffer and a quick heat exchanger also guarantees a high production of domestic hot water. Storage water temperature (50-55°C) is also ideal for maximizing performance and efficiency levels of the heat pump.



WIRING DIAGRAM FOR PUFFER CONNECTIONS

NEW FRONTIER ENERGY CLASS A++

HIGH ENERGY EFFICIENCY.

Energy class A++, in compliance with UE ECOLABEL 811/2013 rules, results from adding efficiencies of condensation boiler of the latest generation, of heat pump with inverter, and of Smart Easy or Smart Web remote controls. Global efficiency of the system is shown on final label.

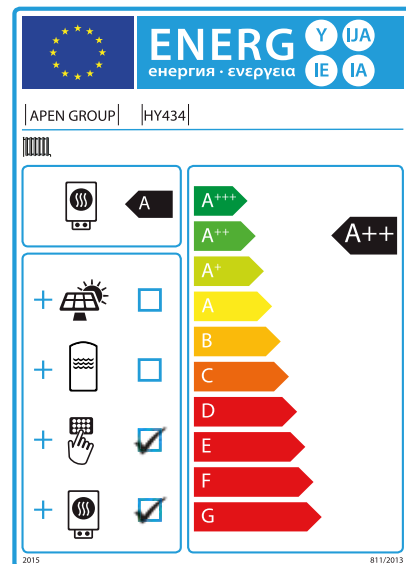

ADVANCED CONTROL WITH TOUCH-SCREEN SMART SYSTEM

Smart Easy (standard) or Smart Web (upon request) remote controls with touch screen work as stand-alone chronothermostats (when a thermoventilation unit is installed).

They include a control for hot domestic water if a tank is installed.

Connection is simple and requires two polarized cables.

The remote control can be recessed into the wall or hanged on it. You can install up to three remote sensors in addition to the one in the remote control.

Use is easy, with a 4.3" color display and an intuitive administration menu.

User program is available in 9 languages.

Ease of installation, clear and intuitive administration menu, four temperature value readings in the controlled area make these chronothermostats versatile and suitable to different installation types and needs.

SMART WEB / SMART EASY FOR ANY NEEDS



TECHNICAL FEATURES

TECHNICAL FEATURES

Condensing boiler:

- Premix burner with low NOx emissions, class 6, compliant with EN15502-1 norm.
- Heat exchanger in Low-Carbon stainless steel.
- Self-checking electronic device with microprocessor: it monitors all burner controls and commands.
- Compliant with all EC applicable regulations.

Inverter Heat Pump

- Fan's motor DC inverter.
- Twin Rotary compressor DC inverter with permanent-magnets.
- Refrigerant gas: R410A.
- Source exchanger with coil made with copper tubes and aluminum hydrophilic treated flaps..

Hydraulic system:

- Manometer for equipment pressure control.
- NTC sensors for water temperature regulation.
- Thermometer for hydraulic circuit temperature control.
- Flow meter to measure water flow rate in the system.
- Brushless circulator with variable-displacement CC motor and built-in automatic air separator (degasser).
- Safety thermostat (90°C).
- System safety valve (3 bar).
- IPX5D protection degree.
- Expansion tank (8 l).

STANDARD ACCESSORIES

- Flue gas outlet kit.
- Kit for conversion to GPL.

SMART EASY FEATURES

AquaPump Hybrid can only work with Smart Easy touch screen remote control, which manages combined operation of the two technologies through MOD-BUS RTU communication protocol.

NOTE FOR SMARTWEB

You can ask for SMARTWEB configuration for your remote control, which allows controlling the unit through a PC interface.



DATASHEET

				HY434IT Single phase	HY534IT Three-phase
Heat Pump	Heating	Output power (MIN-MAX) ¹	kW	5,5 - 15,1	5,5 - 15,1
		COP ¹	W/W	4,3	4,3
		Output power ²	kW	14,90	14,90
		COP ²	W/W	3,35	3,35
	Conditioning	Output power ³	kW	15,20	15,20
		EER ³	W/W	4,70	4,70
		Output power (MIN-MAX) ⁴	kW	12,05	12,05
		EER ⁴	W/W	3,10	3,10
Boiler	Furnace output power [MIN-MAX]		kW	8,0 - 34,8	8,0 - 34,8
	Output power ⁵ [min-max]		kW	8,6 - 36,8	8,6 - 36,8
	Efficiency ⁵		%	106,9 - 105,8	106,9 - 105,8
	Output power ⁶ [min-max]		kW	8,5 - 36,2	8,5 - 36,2
	Efficiency ⁶		%	106,3 - 103,9	106,3 - 103,9
	Power rating [min-max]		W	90 - 130	90 - 130
General Data	Power supply		V/Hz/F	230/50/1F	400/50/3F
	Power input ⁷		kW	7,7	7,7
	Absorbed max current		A	32,8	10,9
	Gas supply fitting		Ø	3/4" M	3/4" M
	Hydraulic system fitting		Ø	1" M	1" M
	Sound pressure ⁸		dbA	57,5	57,5
	Weight		kg	165	170

1. Outdoor air temp. 7°C D.B.T. /6°C W.B.T.; water temp. in/out 30/35°C ;
2. Outdoor air temp. 7°C D.B.T. /6°C W.B.T.; water temp. in/out 40/45°C;
3. Outdoor air temp. 35°C temp. water in/out 23/18°C;
4. Outdoor air temp. 35°C temp. water in/out 12/7°C;

5. Calculated on LHV with water at 50/30°C;
6. Calculated on LHV with water at 60/35°C;
7. Outdoor air temp. 7°C D.B.T. /6°C W.B.T.; water temp. heat pump in/out 30/35°C;
8. Average sound pressure level in free field at 1 m from appliance according to ISO 3744.



DIMENSIONS

SMALL SIZE, HIGH CAPACITY

The integrated compact unit (boiler + heat pump) is the same size as a heat pump. The inverter technology and a new generation of compressors and fans, stemming from most recent research work by leading manufacturers, assure unprecedented levels of silent operation.

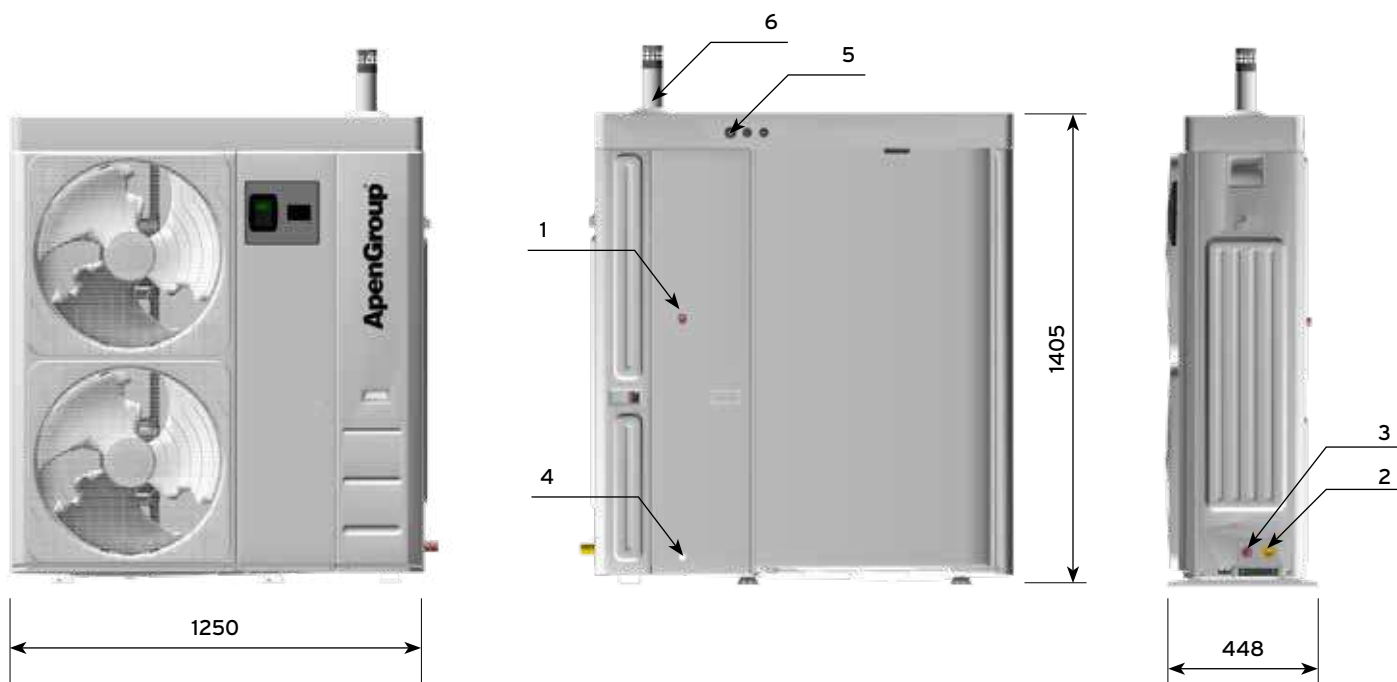

Description	Dimensions
1 GAS SUPPLY	G3/4"
2 WATER RECIRCULATION	G1"
3 WATER DELIVERY	G1"
4 CONDENSATE DRAIN	Ø19 mm
5 ELECTRICAL CONNECTIONS	PG09 x 2 + PG13 x 1
6 FLUE EXHAUST CHIMNEY	60 mm



APEN GROUP S.p.a.
Via Isonzo, 1- Pessano con Bornago
20060 (Milano) - Italy
Tel +39 02 95 96 931 Fax +39 02 95 74 27 58
www.apengroup.com apen@apengroup.com
Cod.X01810GB ed.A1901
Apen Group reserves the right to modify this catalogue content without notice.